

CUSTOMER PART No.

CUSTOMER

CAN ART STD.

DIE No.

EH05743

DESCRIPTION

2" x 1" x .100" RECT. TUBE

PROPOSAL No.

H-11833

NOTE: BREAK ALL CORNERS WITH 0.015" (.38 MM) RADIUS UNLESS OTHERWISE NOTED. STANDARD TOLERANCES TO APPLY UNLESS OTHERWISE SPECIFIED.

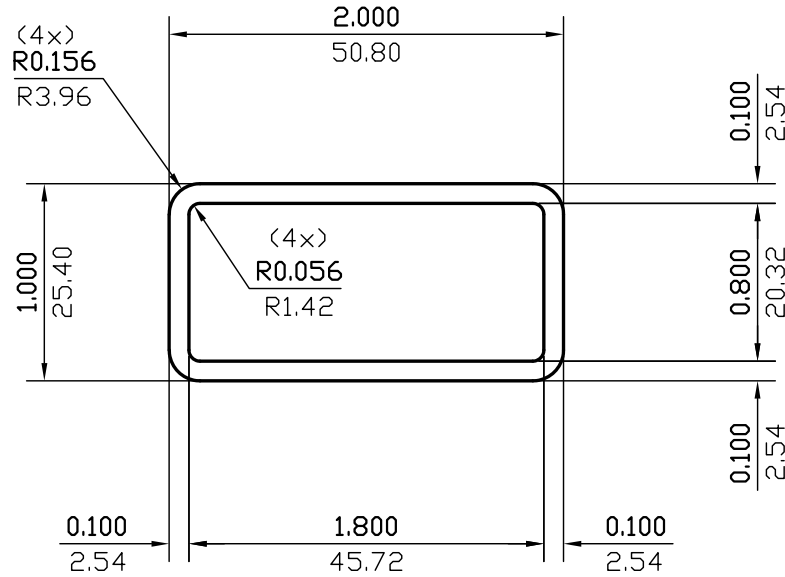

WALL THICKNESS AS SHOWN EXCEPT AS SHOWN

DATE	REV	DESCRIPTION	BY
03/15/23	1	REMOVED ALLOY	JASON
EST.AREA	0.542	IN. ²	EST.AREA 349.552
			MM. ²
EST.WT.	0.639	LBS/FT.	EST.WT. 0.951
			KG/M.
EST.PER.	10.836	IN.	EST.PER. 275.235
			MM.
OUT PER.	5.732	IN.	OUT PER. 145.6
			MM.
C.C.D.	2.136	IN.	C.C.D. 54.251
			MM.
FACTOR	17	FINISH	M/F
		ALLOY & TEMP.	
CKD BY	SCALE	1:1	DWN BY C.P. DATE 01/11/2002

CAN ART

ALUMINUM EXTRUSION INC.

85 PARKSHORE DRIVE
BRAMPTON, ONT L6T 5M1
TEL. NO. (905) 791-1464
FAX NO. (905) 791-9151
E-MAIL: canart@canart.com

THIS DRAWING IS NOT NECESSARILY A COPY OF YOUR ORIGINAL. PLEASE APPROVE DIMENSIONS AND TOLERANCES INDICATED. CAN ART ASSUMES NO RESPONSIBILITY EITHER TECHNICAL OR LEGAL FOR HAVING THIS SHAPE MADE. THE CUSTOMER AGREES TO FULLY PROTECT CAN ART ALUMINUM FROM CLAIMS OF OTHERS RESULTING FROM THIS SHAPE.

SIGNED: _____ DATE: _____